

The Automatic Power System sensor is a highly sensitive, photoelectronic precision instrument that is capable of analysing the state of the skin accurately and reliably. For this reason, the IQ sensor is automatically tested for proper working order and measurement accuracy after every measurement cycle. It is also recommended to recalibrate the APS sensor after approximately 30 hours of operation. For further information refer to the operating instructions.



Advantage 400 APS

Contents

Device description	2
Technical Data	2
Dimensions	3
Maximum exhaust pipe lengths	4
Equipment cooling	4
Surround cooling	5
Exhaust air accessories	5
Electrical connections	6
Sound system	6
Controls	6
Air conditioner	6
IR Interface	6
APS sensor	7

Device description

1. Face tanner (UV high-pressure lamps)
2. Loudspeaker
3. Headphone connection
4. APS sensor and base station
5. Reflector
6. UV low-pressure lamps, lower part
7. Intermediate panel (only with air conditioner)
8. Infrared interface
9. Acrylic glass panel lower part
10. UV low-pressure lamps, canopy
11. Air nozzles body cooling
12. Air nozzles body cooling head end
13. Central exhaust air bracket (optional)
14. Accent lighting canopy
15. Accent lighting front panel
16. Accent lighting interal

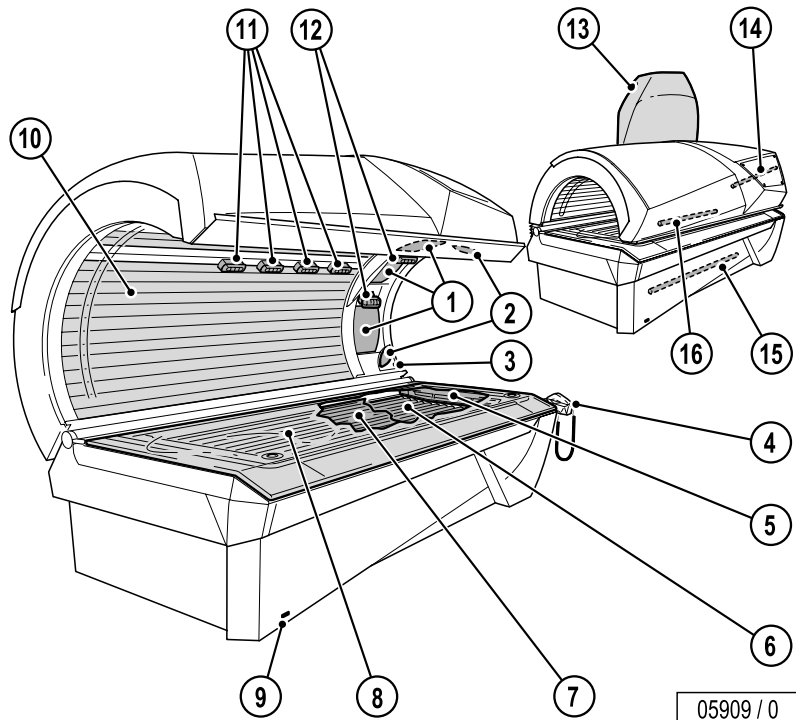

05909 / 0

Technical Data

Electrical data	
Nominal power consumption:	
without Air conditioning:	9700 W
with Air conditioning:	10700 W
Nominal voltage:	400 – 415 V ~3N
Nominal frequency:	50 Hz
Rated fusing:	
without Air conditioning:	3 x 20 A (time-delay)
with Air conditioning:	3 x 25 A (time-delay)
Performance:	
Canopy:	
UV low pressure lamps	26 x 140 (160) W
UV high pressure lamps	3 x 400 W
Lower part:	
UV low pressure lamps	14 x 140 (160) W

Noise emission	
Acoustic pressure level:	66.4 db (A)
Inlet and exhaust air	
Temperature difference, supply/exhaust air:	
without Air conditioning:	7 °C
with Air conditioning:	10 °C
Max. air requirement:	2700 m³/h
Opt. ambient temperature:	25 °C – 30 °C
Max. ambient temperature:	15 °C – 40 °C
Max. inlet air temperature:	40 °C
Exhaust cross section w/o exhaust system:	430 cm²
Cabin inlet air cross section at 1.5 m/s:	5000 cm²
Exhaust cross section with exhaust system:	710 cm²
Warm air return:	possible

Dimensions

B-	1310 mm
B1	1180 mm
B2	1300 mm
B+	1430 mm
L	2300 mm
L1	2015 mm
L2	1615 mm
L3	35 mm
L4	273 mm
L5	867 mm
L6	1100 mm
H	1256 mm
H1	1575 mm
H2	390 mm
H3	- mm
H4	264 mm
H5	167 mm
H6	1679 mm
H7	1760 mm
H8	1979 mm
H9	2124 mm
X	1220 mm
Y	673 mm
Z	2226 mm
∅	300 mm
BK	2400 mm
TK	2100 mm

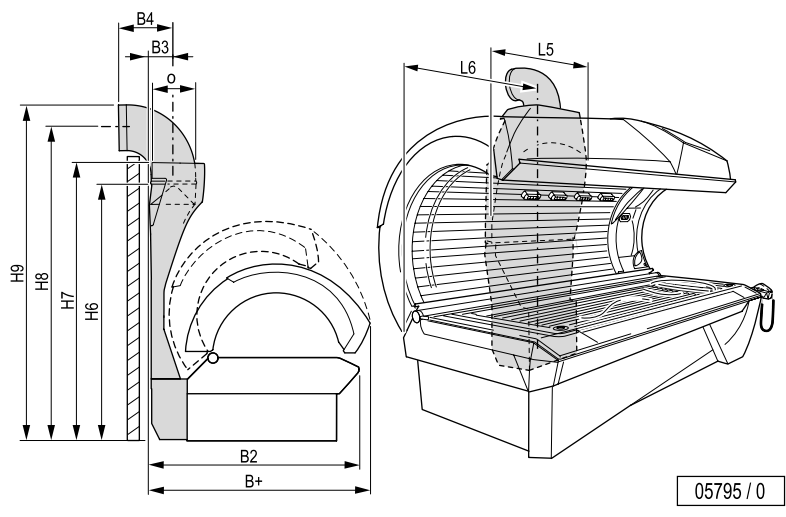
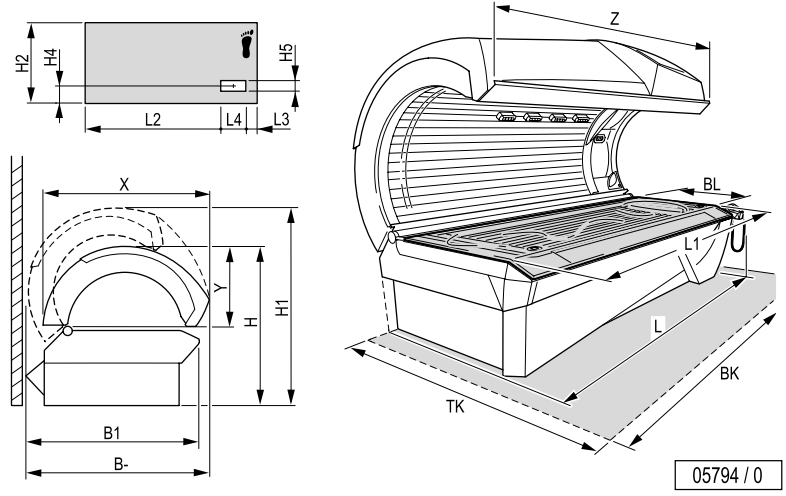

Maximum exhaust pipe lengths

Calculation base (without additional ventilator):

Back pressure	100 Pascal
Air pressure	100,000 Pascal
Air temperature	40 °C
Density	1.112 kg/m ³
Dynamic inertia of the air	1.92E-05 Pa x s

Corrugated pipe ∅	Roughness (at centre) k _{absolute}	Flow volume	Loss coefficient		90° bend in line (metal)	Permissible length of straight line
mm	mm	m ³ /h	of pipe	of bend	pieces	m
300	8	2300	0.182 ¹⁾	0.21 ¹⁾	0	12
					1	11
					2	10
					3	9
Smooth pipe ∅	Roughness (at centre) k _{absolute}	Flow volume	Loss coefficient		90° bend in line (metal)	Permissible length of straight line
mm	mm	m ³ /h	of pipe	of bend	pieces	m
300	0.1	2300	0.061 ¹⁾	0.21 ¹⁾	0	36
					1	33
					2	29
					3	26

1) zeta value (ζ)

Equipment cooling

Cabin or studio air is drawn in beneath the front panel (1) of the lower part of the sunbed and over the filter mats in the canopy (2) (inlet air) in order to cool the equipment.

The inlet air is first cleaned in a filter, then fed past the hot UV low-pressure and high-pressure lamps and finally expelled as warm exhaust air via the central exhaust air bracket (3) at the rear of the sunbed.

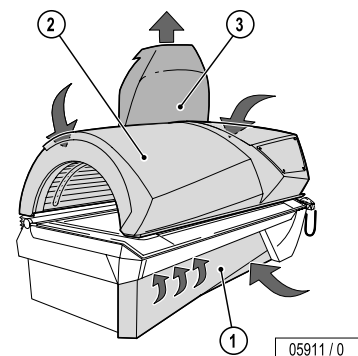

05911 / 0

Surround cooling

Surround air ventilation for the user is provided automatically. The intensity is adjustable in 9 steps. Cabin or studio air is drawn in and used for cooling.

The air is fed through several nozzles in the middle of the canopy and in the head area.

Depending on the equipment, an air conditioner enables the additional climate control of the bed surface and the body air.

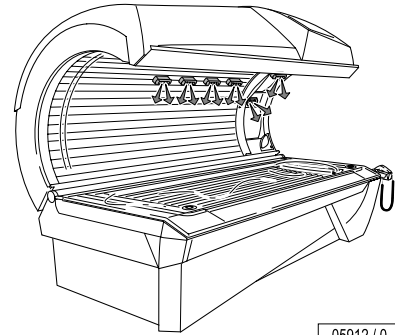

05912 / 0

Exhaust air accessories

Connection to a central exhaust system is possible upwards, upwards right, upwards left and to the rear.

The apertures intended for this purpose are located above the central exhaust air bracket.

Corrugated pipe

Suitable device exhaust is possible with an exhaust pipe up to 12 metres in length (without 90° bend). An auxiliary fan is required for exhaust pipes longer than 12 metres.

Smooth pipe

Suitable device exhaust is possible with an exhaust pipe up to 36 metres in length (without 90° bend). An auxiliary fan is required for exhaust pipes longer than 36 metres.

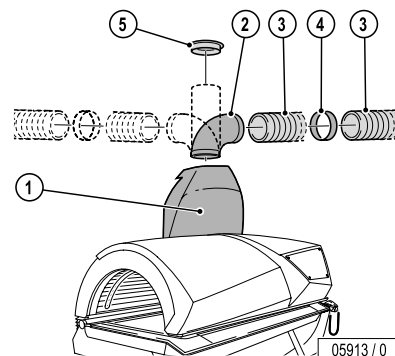

05913 / 0

Warm air recycling

Warm air recycling is a technically advanced, secure device which feeds part of the hot cooling air back to the studio via a motor-controlled air choke. A thermostat provides fully automatic control of the studio temperature, between 15 °C and 25 °C as required.

The exhaust air bracket and warm air recycling can also be retrofitted.

Item	Accessory parts	Article No.	Notes
1	Central exhaust air bracket Techno Grey with warm air recycling, thermostatically controlled including connector piece, see Item 4	3452840	With connection possible for exhaust air pipes (∅ 300 mm) on the top, top right, top left and to the rear
	Central exhaust air bracket Techno Grey, but without warm air recycling	3452830	
2	90° Pipe bend in Techno Grey	3452110	For inlet and exhaust air ducting to right, left or to rear, plus tube adapter for direct connection to central exhaust air bracket [possible with tube (∅ 300 mm)]
3	Corrugated pipe (∅ 300 mm, 6 m length, flexible, grey) including 2 pipe clamps	3450280	–
4	Corrugated pipe connector piece (∅ 300 mm)	3450270	For connecting two corrugated pipes
5	Connector bracket for corrugated pipe (∅ 300 mm)	3450360	Connection of the corrugated pipes, e.g. to a canal

Electrical connections

Mains supply line	none
Electr. control line	none
Line for external music and channel selection	none

Sound system

Equipment variant, retrofitting not possible.

Controls

Control	Article No.	Notes
MCS III plus hand-held remote control	3401060	With chip card terminal
ICS-Unit	3453200	Chip card terminal for APS devices
MCS IV plus	3401040	With electronic coin tester
MCS VI	3400970	With electronic coin tester + chip card terminal
Studiopilot	3400990	With electronic coin tester + chip card terminal
Studio-Manager	3452900	Software

Air conditioner

Equipment variant: Air condition for the bed surface and the body air, retrofitting not possible.

IR Interface

Standard equipment: Access to the device data with a hand-held unit (Palm).

APS sensor

Standard equipment: The user determines his tanning ability by using the integrated APS sensor to measure face and body. When operating the sensor, the user is assisted by VoiceGuide.

Step one: The first measurement is performed on the forehead. A beep confirms a successful measurement. The VoiceGuide then prompts you to perform the second measurement, this time on your body.

Step two: Perform the second measurement on the palest part of your body: e.g. your buttocks or insides of your arms. It's important that this part of the body is included in your tanning assessment. This way, allowance is made for pigmentation progress at the next tanning session and tanning power is increased.

The Automatic Power System now takes just a few seconds to compute your personal tanning programme from your measurement readings.

Step one ...



Step two ...

