

The Automatic Power System sensor is a highly sensitive, photoelectronic precision instrument that is capable of analysing the state of the skin accurately and reliably. For this reason, the IQ sensor is automatically tested for proper working order and measurement accuracy after every measurement cycle. It is also recommended to recalibrate the APS sensor after approximately 30 hours of operation. For further information refer to the operating instructions.



Excellence 700 APS

Contents

- Device description 2
- Technical Data 2
- Dimensions 3
- Planning example for double rear wall 4
 - With exhaust-air adapter 4
 - Without exhaust-air adapter 4
- Maximum exhaust pipe lengths 5
- Equipment cooling 6
- Surround cooling 6
- Exhaust air accessories 7
- Electrical connections 8
- MULTIVISION 8
- Sound system 8
- Controls 8
- Air conditioner 8
- AQUA FRESH AROMA system 8
- IR Interface 8
- APS sensor 9

Device description

1. Face tanner (UV high-pressure lamps)
2. Shoulder tanner
3. APS sensor and base station
4. Neck tanner
5. Headphone connection
6. UV low-pressure lamps, lower part
7. Intermediate panel
8. Infrared interface
9. Acrylic glass panel lower part
10. Air nozzles body cooling, feet end
11. UV low-pressure lamps, side part
12. UV low-pressure lamps, canopy
13. Nozzles AQUA FRESH
14. Air nozzles body cooling
15. Air nozzles body cooling head end and AROMA
16. Central exhaust air bracket (optional)
17. Accent lighting canopy (two coloured)
18. Accent lighting canopy
19. Accent lighting base
20. Accent lighting front panel (blue)
21. Accent lighting internal (blue)

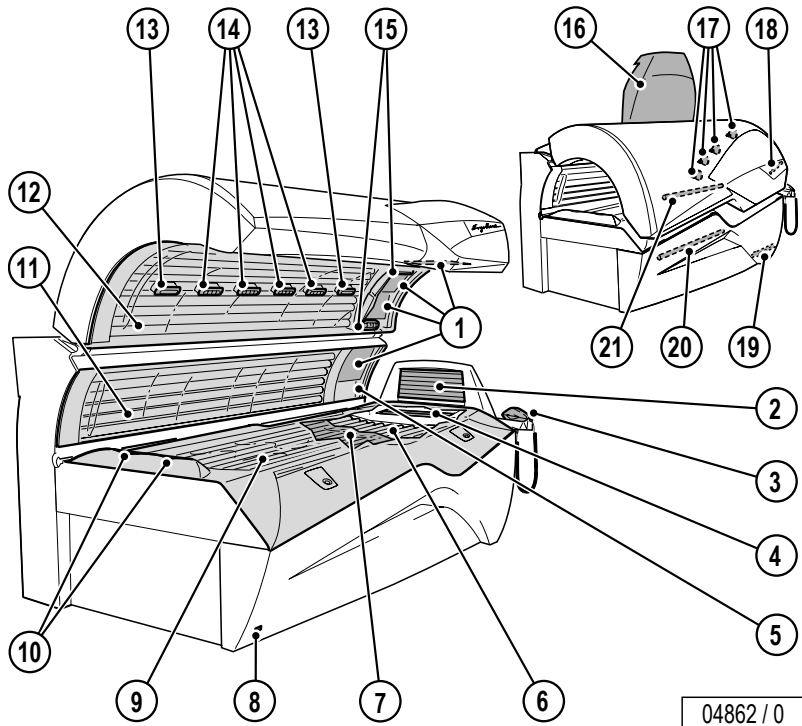

Technical Data

Electrical data	
Nominal power consumption:	18300 W
Nominal voltage:	400 – 415 V ~3N
Nominal frequency:	50 Hz
Rated fusing:	3 x 35 A (time-delay)
Performance:	
Canopy:	
UV low pressure lamps	24 x 160 W
UV high pressure lamps	3 x 520 W
Lower part:	
UV low pressure lamps	19 x 160 W
Side part:	
UV low pressure lamps	8 x 160 W
UV high pressure lamps	1 x 520 W
Neck tanner:	
UV low pressure lamps	6 x 25 W
Shoulder tanner:	
UV low pressure lamps	7 x 25 W

Noise emission	
Acoustic pressure level:	68.9 db (A)
Inlet and exhaust air	
Temperature difference, supply/exhaust air:	15 °C
Max. air requirement:	2800 m³/h
Opt. ambient temperature:	25 °C – 30 °C
Max. ambient temperature:	15 °C – 40 °C
Max. inlet air temperature:	40 °C
Exhaust cross section w/o exhaust system:	588 cm²
Cabin inlet air cross section at 1.5 m/s:	5200 cm²
Exhaust cross section with exhaust system:	710 cm²
Warm air return:	possible

Dimensions

B	1428 mm
B1	850 mm
B2	188 mm
B+	1510 mm
L	2323 mm
L1	2110 mm
L2	1730 mm
L3	238 mm
L4	265 mm
L5	867 mm
L7	1116 mm
H	1373 mm
H1	1830 mm
H2	1078 mm
H3	- mm
H4	400 mm
H5	114 mm
H6	1887 mm
H7	1974 mm
H8	2197 mm
H9	2342 mm
X	1224 mm
Y	472 mm
Z	2235 mm
∅	300 mm
BK	2370 mm
TK	2300 mm

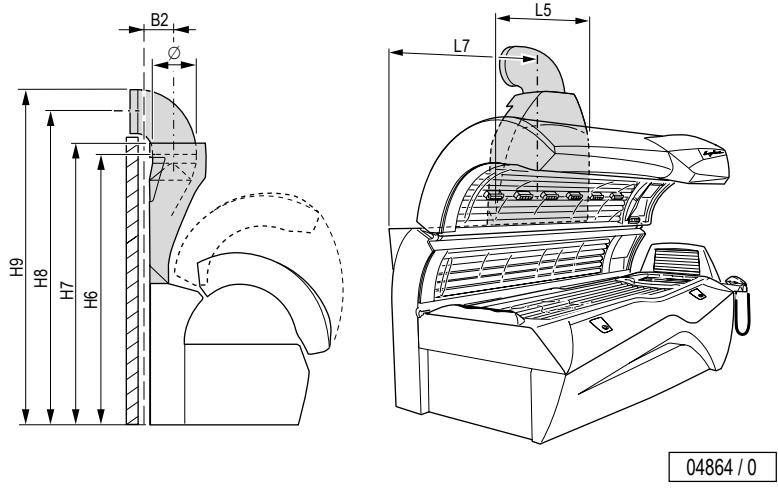
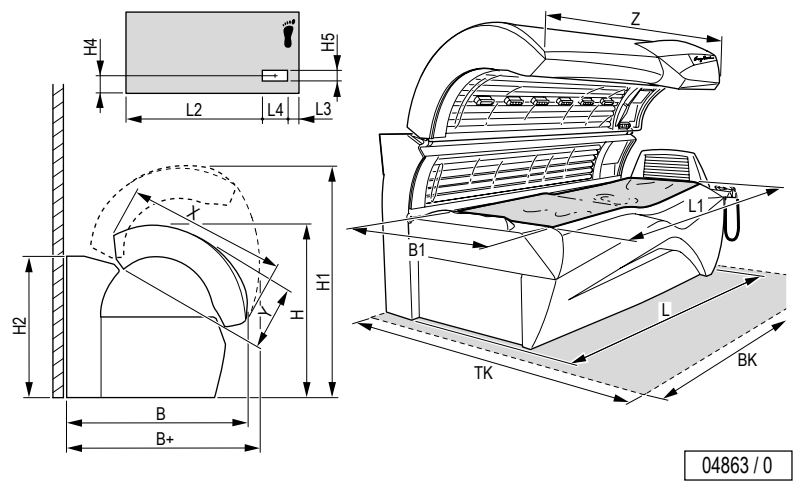

Planning example for double rear wall

Installing “exhaust air ducting via a suspended ceiling and with a double rear wall” is an optically elegant solution without using the central exhaust air bracket.

An intermediate wall (1) (e.g. chipboard) tightly enclosing the sunbed at the rear serves as an upward channel for the exhaust air (2), if required right up to the suspended ceiling. So that the exhaust air is properly extracted, a slight vacuum is required behind the intermediate wall (1); an auxiliary fan must be installed if necessary.

With exhaust-air adapter

A cut-out must be made in the intermediate wall (see table for dimensions). A rubber profile on the exhaust-air adapter (3) ensures an air-tight seal on the intermediate wall.

Dimensions		
L1	1116 mm	Tanning bed foot end up to centre of adapter
L2	590 mm	Long adapter, inner edges
H	1355 mm	Height from floor to inner upper edge of rubber profile
H1	1125 mm	Height from floor to inner lower edge
H2	230 mm	Height of adapter (inside)

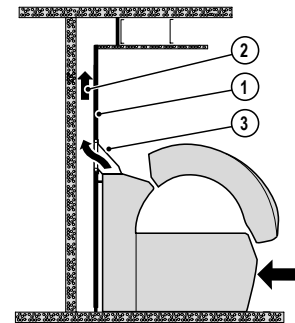

03834 / 0

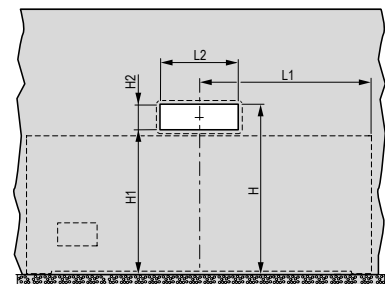

03840 / 0

Without exhaust-air adapter

The intermediate wall (1) must securely enclose the rear of the tanning bed.

Dimensions	
B1	max. 170 mm
B2	57 mm
H1	1078 mm

If a tanner is replaced with a new tanner, the intermediate wall (1) must be adapted or replaced so that there are no gaps through which leakage air is drawn. Provision must be made for the inspection doors at the head and foot of the tanner so that the canopy lifting device can be adjusted.

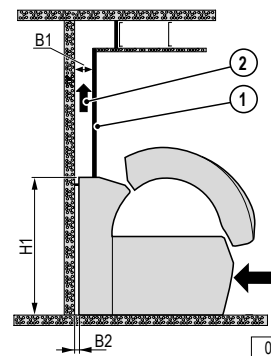

03985 / 0

Maximum exhaust pipe lengths

Calculation base (without additional ventilator):

Back pressure	100 Pascal
Air pressure	100,000 Pascal
Air temperature	40 °C
Density	1.112 kg/m ³
Dynamic inertia of the air	1.92E-05 Pa x s

Corrugated pipe ∅	Roughness (at centre) k _{absolute}	Flow volume	Loss coefficient		90° bend in line (metal)	Permissible length of straight line
mm	mm	m ³ /h	of pipe	of bend	pieces	m
300	8	2500	0.182 ¹⁾	0.21 ¹⁾	0	10
					1	9
					2	8
					3	7
Smooth pipe ∅	Roughness (at centre) k _{absolute}	Flow volume	Loss coefficient		90° bend in line (metal)	Permissible length of straight line
mm	mm	m ³ /h	of pipe	of bend	pieces	m
300	0.1	2500	0.061 ¹⁾	0.21 ¹⁾	0	30
					1	26
					2	22
					3	18

1) zeta value (ζ)

Equipment cooling

Cabin or studio air is drawn in beneath the front panel (1) of the lower part of the sunbed and over the filter mats in the canopy (2) (inlet air) in order to cool the equipment.

The inlet air is first cleaned in a filter, then fed past the hot UV low-pressure and high-pressure lamps and finally expelled as warm exhaust air via the central exhaust air bracket (3) at the rear of the sunbed.

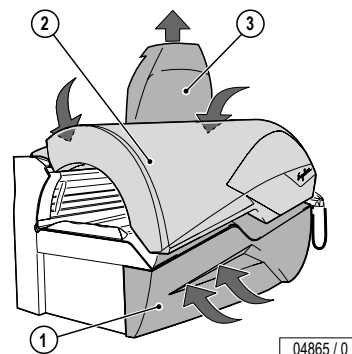

Surround cooling

Surround air ventilation for the user is provided automatically. The intensity is adjustable in 9 steps. Cabin or studio air is drawn in and used for cooling.

The air is fed through several nozzles over the whole length in the middle of the canopy. In the head area there are two air nozzles that can be switched on separately.

Studio air is also supplied via the air inlet slots beneath the front panel of the sunbed base and fed to two nozzles at feet level at the lying surface height, thus surrounding the body with cooling air.

The user can have a pleasant cooling mist (AQUA FRESH) sprayed from the outer nozzles in the body area.

In automatic mode the initial temperature of the air conditioner (Climatronic, standard equipment) is automatically preselected dependent on the lamp power.

In maximum mode the user can preselect the temperature of the air conditioner (Climatronic, standard equipment).

The temperature of the air conditioner can be adjusted at any time during the tanning.

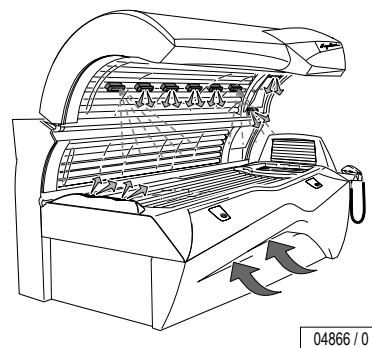

Exhaust air accessories

Connection to a central exhaust system is possible upwards, upwards right, upwards left and to the rear.

The apertures intended for this purpose are located above the central exhaust air bracket.

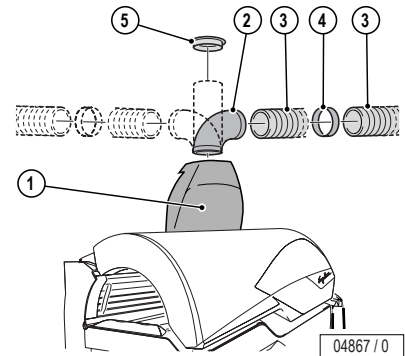

Corrugated pipe

Suitable device exhaust is possible with an exhaust pipe up to 10 metres in length (without 90° bend). An auxiliary fan is required for exhaust pipes longer than 10 metres.

Smooth pipe

Suitable device exhaust is possible with an exhaust pipe up to 30 metres in length (without 90° bend). An auxiliary fan is required for exhaust pipes longer than 30 metres.

Warm air recycling

Warm air recycling is a technically advanced, secure device which feeds part of the hot cooling air back to the studio via a motor-controlled air choke. A thermostat provides fully automatic control of the studio temperature, between 15 °C and 25 °C as required.

The exhaust air bracket and warm air recycling can also be retrofitted.

Item	Accessory parts	Article No.	Notes
1	Central exhaust air bracket Techno Grey with warm air recycling, thermostatically controlled including connector piece, see Item 4	3452620	With connection possible for exhaust air pipes (∅ 300 mm) on the top, top right, top left and to the rear
	Central exhaust air bracket Techno Grey, but without warm air recycling	3452630	
2	90° Pipe bend in Techno Grey	3452110	For inlet and exhaust air ducting to right, left or to rear, plus tube adapter for direct connection to central exhaust air bracket [possible with tube (∅ 300 mm)]
3	Corrugated pipe (∅ 300 mm, 6 m length, flexible, grey) including 2 pipe clamps	3450280	–
4	Corrugated pipe connector piece (∅ 300 mm)	3450270	For connecting two corrugated pipes
5	Connector bracket for corrugated pipe (∅ 300 mm)	3450360	Connection of the corrugated pipe, e.g. to a canal
6	Exhaust air adapter in black (not shown)	3452660	For double rear wall

Electrical connections

Mains supply line	none
Electr. control line	none
Line for external music and channel selection	none

MULTIVISION

Equipment variant, retrofitting not possible.

Sound system

Standard equipment.
3D sound: Equipment variant, retrofitting not possible.

Controls

Control	Article No.	Notes
MCS III plus hand-held remote control	3401060	With chip card terminal
ICS-Unit	3453200	Chip card terminal for APS devices
MCS IV plus	3401040	With electronic coin tester
MCS VI	3400970	With electronic coin tester + chip card terminal
Studiopilot	3400990	With electronic coin tester + chip card terminal
Studio-Manager	3452900	Software

Air conditioner

Standard equipment: Climatronic for bed surface and Surround Cooling with fully integrated climate control of body cooling; Cabin climate control via body cooling run-on (temperature-controlled).

AQUA FRESH AROMA system

Standard equipment: Aroma and body cooling for the user.

IR Interface

Standard equipment: Access to the device data with a hand-held unit (Palm).

APS sensor

Standard equipment: The user determines his tanning ability by using the integrated APS sensor to measure face and body. When operating the sensor, the user is assisted by VoiceGuide.

Step one: The first measurement is performed on the forehead. A beep confirms a successful measurement. The VoiceGuide then prompts you to perform the second measurement, this time on your body.

Step two: Perform the second measurement on the palest part of your body: e.g. your buttocks or insides of your arms. It's important that this part of the body is included in your tanning assessment. This way, allowance is made for pigmentation progress at the next tanning session and tanning power is increased.

The Automatic Power System now takes just a few seconds to compute your personal tanning programme from your measurement readings.

Step one ...



Step two ...

